

American Guild of Organists

Console Specifications

PEDALBOARD

Compass: 32 notes, CCC to G

Radiation: 8 ft. 6 in. radius, Maximum permissible, 9 ft. 6 in., minimum 8 ft. 6 in.

Concavity: 8 ft. 6 in. radius, Maximum 8 ft. 6 in., minimum 7 ft. 6 in.

Length between heelboard and toeboard: 27 in.

Length of playing surface of sharps: 6 1/2 in.

Height of sharps above naturals: 1 in. at player's end, 1/2 in. higher at the other.

Width of playing surface of natural keys: 7/8 in. - 15/16 in.

Radius of curve of sharps: Fronts, 8 ft. 6 in., back 9 ft.

Distance, center to center of adjacent natural keys at front end of sharps: 2 1/2 in. This makes the octave 17 1/2 in. Most important of all the measurements, it is important that this distance be maintained.

Depth of touch: 1/2 in. at front line of sharps

Weight of touch: 2 1/2 to 3 pounds at front line of sharps.

Point of speech: Midway between top and bottom of travel of the pedal keys.

Couplers: Manuals to pedals 8' and 4' from each manual to pedal (except only 8' on great). Reversible pistons operating either pedal or manual couplers should add 8' couplers but remove both 8' and 4' couplers. Great to Pedal Reversible duplicated by toe stud at right of crescendo shoe.

PEDAL TO MANUAL

Left to right location: Centered under the manuals.

Front to back: Pedal DD-sharp's front end 8 1/2 in. to 10 in. back of plumb line dropped from edge of white keys of lowest manual of two manual or three manual console, 11 in. on a four manual.

Vertical: 29 1/2 in. between playing surface of natural keys of lowest manual and middle natural key of pedal.

PEDAL ACCESSORIES

Knee panel and toe-board carrying the pedal accessories to follow the 9 ft. radius curve of the distant end of the sharp keys.

Crescendo shoes: Heel end of playing surface of shoe to overhang sharp keys by 1 1/4 in. maximum forward position, or be placed 3/4 in. maximum distance back of them. These dimensions are for the shoes in closed position.

Swell shoe to be located directly in front of the E-F gap.

Choir or Positiv shoe to left of swell.

Solo shoe to right of swell.

Register-crescendo shoe invariably to the right of all others, and slightly raised.

Great shoe in small two-manual organs, where great is enclosed, to replace choir or Positiv shoe at left of swell shoe.

Bench: Normal height above middle E of pedal clavier, 20 1/2 in., adjustable up or down from this height by as much as 2 in. in either direction by means of a crank.

MANUALS

Compass: CC to c4, 61 notes.

Overhang of the keys: 4 1/4 in. to 2 1/2 in. surface to surface. Manuals may slope toward Great or be level.

Depth of touch: 5/16 in. to 3/8 in. scant.

Point of speech: Midway between top and bottom of travel of the keys.

Weight of touch: 3 1/4 to 3 3/4 ounces with tracker touch recommended on electro-pneumatic instruments.

COUPLERS

All manuals couple to Great and Pedal. Swell couples to Choir or Positive. Choir or Positiv couples to Great,

ORDER OF STOPS

The order within each division is: 16' flues, 8' flues, 4' flues, 2' flues, Mixtures, 16' reeds, 8' reeds, 4' reeds. Stops not mentioned in the above take their normal position according to pitch in their respective flue and reed divisions. Loudest to softest is the order within pitch groups. (Left to right for stop-tabs, bottom to top for draw-knobs).

Stop-tab consoles: Two rows over top manual; top row: left to right; Swell, Choir, Solo or Echo, with couplers of each division following the stops. Lower row: Pedal, Great, Positiv.

Draw-knob consoles: left jamb: Pedal and Swell; right: Solo, Great, Choir, Positiv. Order within the division as given, from bottom to top. Tremulants at top. Intramanual couplers above each division of stops.

Order of couplers above top manual on draw-knob consoles: left to right.

Pedal couplers: Great, Swell, Choir-Positiv, Solo.

Manual couplers: Swell to Great, Choir or Positiv to Great, Solo to Great, Swell to Choir, Solo to Choir, Great to Choir.

COMBINATIONS

It is suggested that where there are 8 or more manual pistons for each manual, that they start under middle C of each manual and be spaced 1 1/8 in. apart. General pistons, divided under Swell and Great manuals, to the left of manual pistons, with space enough between the two groups for Great to Pedal, Swell to Pedal, and Swell to Great reversibles. General pistons to be duplicated by toe studs on the left of crescendo shoes. Pedal pistons by toe studs only on the right of crescendo shoes.

American Guild of Organists Console Specifications

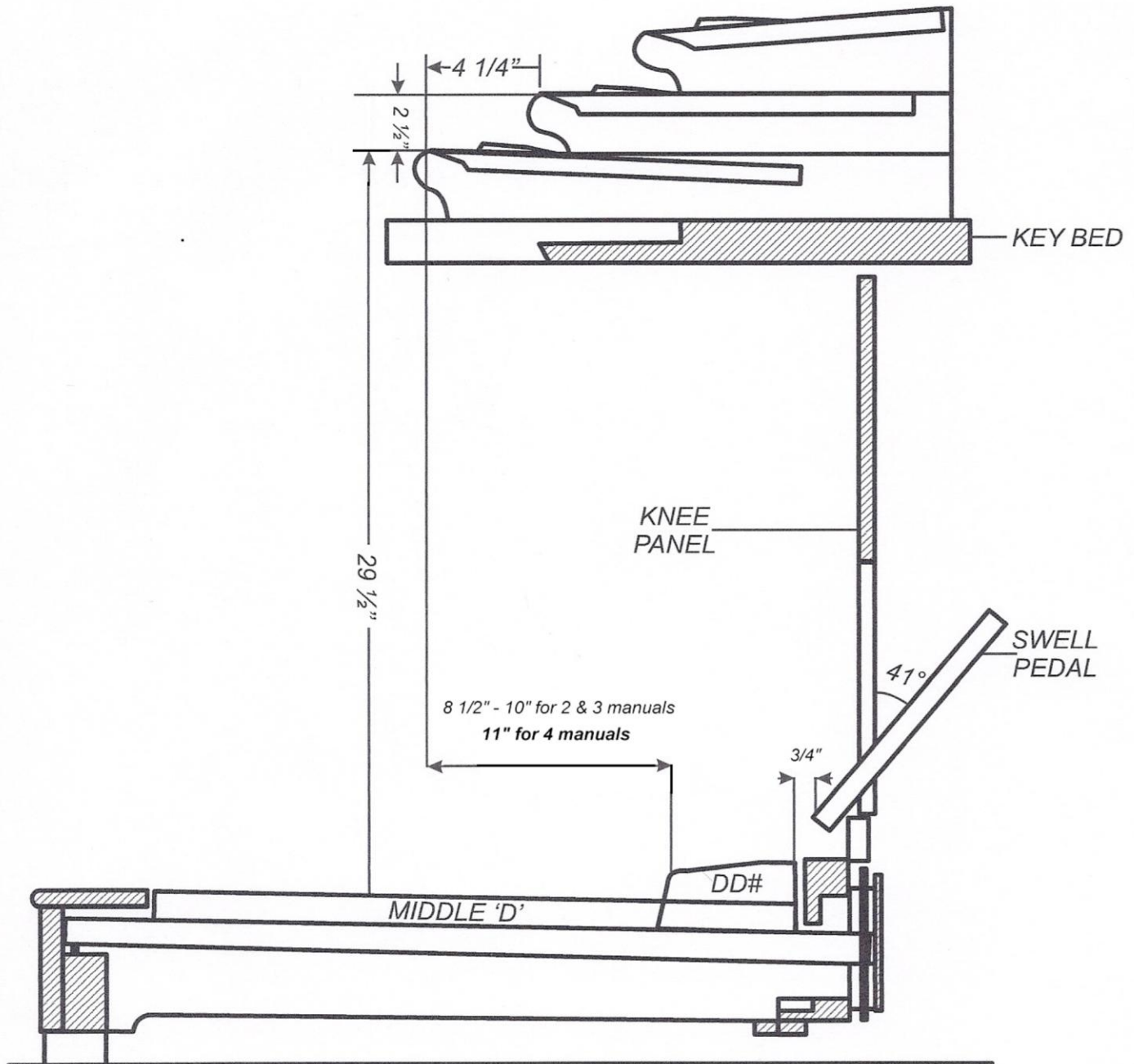

Measurements for Console

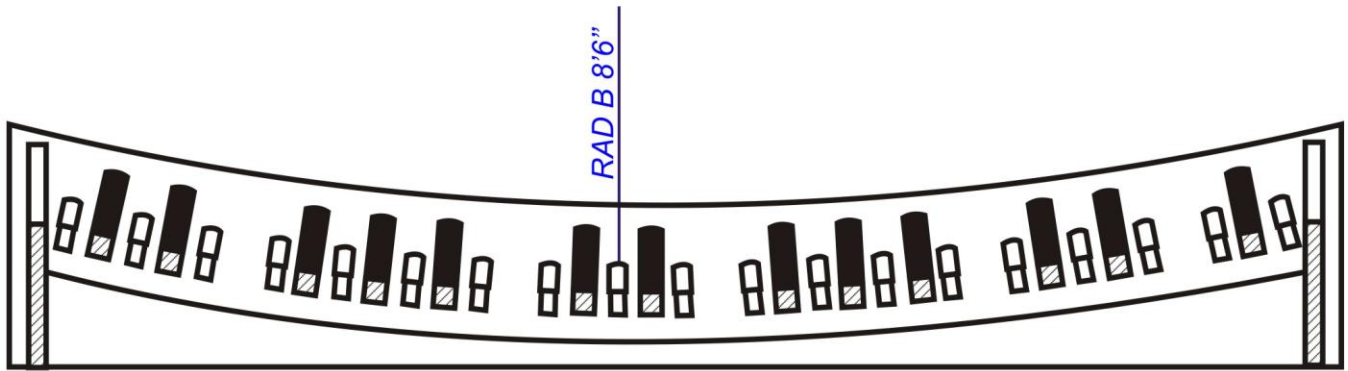

Section at "X-X"

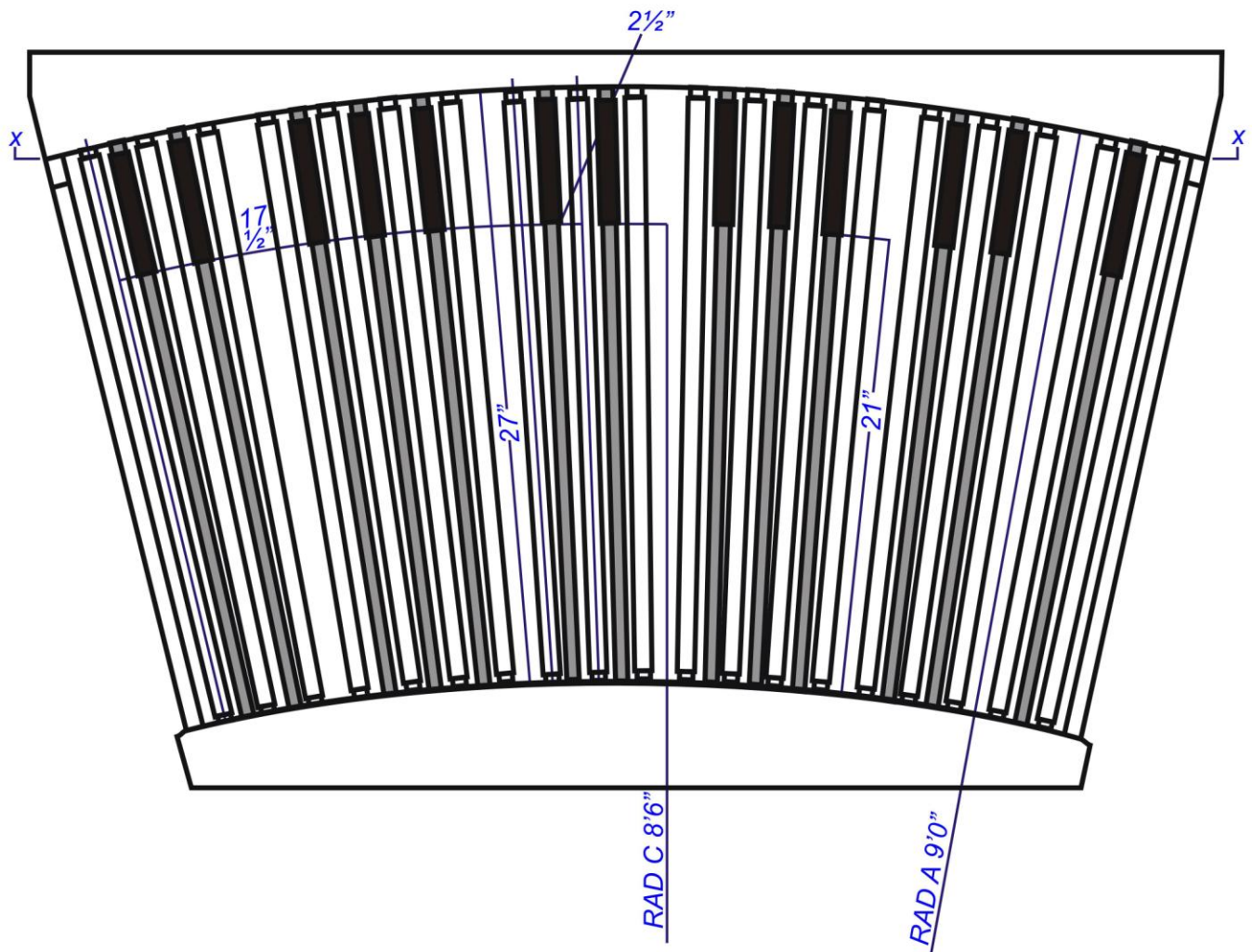

Measurements for Pedalboard